

EBARA

	Page
- SPECIFICATIONS	200
SELECTION CHART	201
TYPE KEY AND CURVE SPECIFICATIONS	202
PERFORMANCE CURVE OPTIMA	203
- CONSTRUCTIONS	300
SECTIONAL VIEW DRAWING	300
SECTIONAL VIEW TABLE	301
MECHANICAL SEAL	302
BEARINGS	302
- DIMENSIONS AND WEIGHT	400
PUMP	400
PACKING	401
- TECHNICAL DATA	500
- INSTALLATION	600
- OPTIONAL	700
MINIMUM SUCTION SYSTEM	700

SPECIFICATION

60Hz

Rev. F

PUMP		
Liquid Handled	Type of liquid	Clear water (Clean water for MS version)
	Max temperature [°C]	50
	Max solids size [mm]	10
Maximum immersion	[m]	2 (with power cable length 5 m) 5 (with power cable length 10 m)
Construction	Impeller	Semi-open centrifugal type
	Shaft seal type	Oil lubricated mechanical seal (pump side) + lip seal (motor side)
	Bearing	Sealed ball bearing
Pipe Connection	Suction	Strainer
	Discharge nozzle [inch]	G1¼": UNI ISO 228
Material	Pump casing	AISI 304
	Impeller	PPE+PS glass fiber reinforced
	Shaft seal	Mechanical seal: Ceramic/Carbon/NBR Lip seal: NBR
	Casing cover	AISI 304
	Shaft	AISI 303 + AISI 303 ceramic coated shaft sleeve
	Lubricating liquid	White mineral oil: Esso Marcol 152
Applicable standard of test		ISO 9906 – Annex A

MOTOR		
Type		Submersible dry type
		Single Phase
No. of Poles		2
Rotation speed	[min ⁻¹]	≈ 3400
Insulation Class		F
Protection degree		IP 68
Power rating	[kW]	0.25
	[HP]	0.33
Frequency	[Hz]	60
Voltage	[V]	110-115 ±6% 220-230 ±6%
Capacitor		Built in
Over load protection		Built in
Casing material		AISI 304
Switch	float	MA version (no maintenance required)
	magnetic	MS version (maintenance required)
Float/magnetic switch cable	material	H07RN-F
	size	3G1
Power cable	length [m]	5 (only for internal usage); 10
	material	H05RN-F
	size	3G0.75
Cable entry		Cable Gland

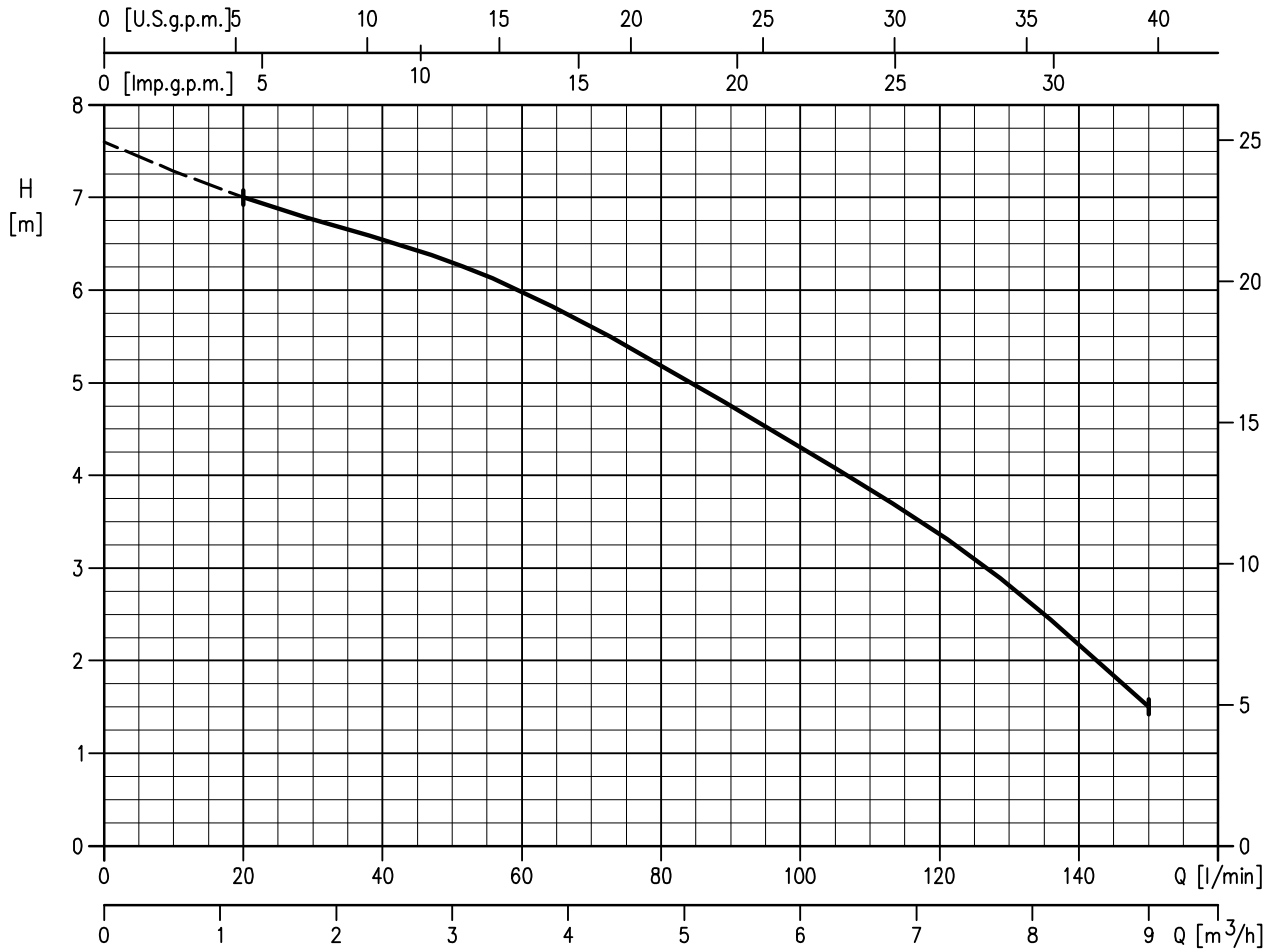

Type pumps	Power		Q=Capacity							
			l/min	0	20	50	75	100	125	150
Single Phase	[kW]	[HP]	m³/h	0	1,2	3	4,5	6	7,5	9
H=Total manometric head in meters										
OPTIMA M	0,25	0,33		7,6	7,0	6,3	5,4	4,3	3,1	1,5

TYPE KEY

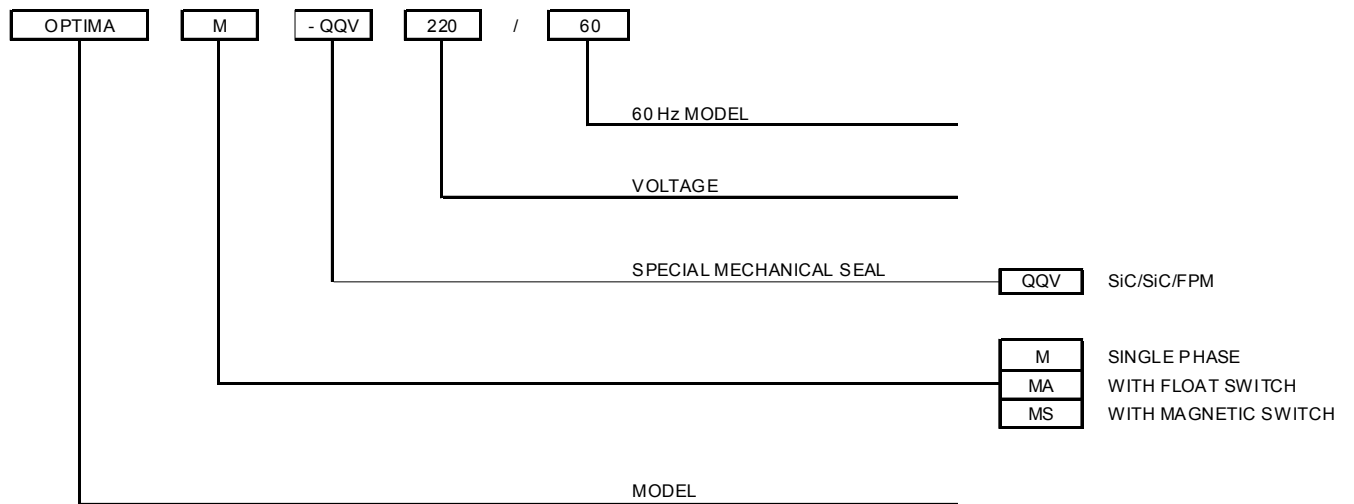

PERFORMANCE CURVE SPECIFICATIONS

The specifications below qualify the curves shown on the following pages.

Tolerances according to ISO 9906 Annex A

The curves refer to effective speed of asynchronous motors at 60 Hz

Measurements were carried out with clean water at 20°C of temperature and with a kinematic viscosity of $\nu = 1 \text{ mm}^2/\text{s}$ (1 cSt)

The continuous curves indicate the recommended working range. The dotted curve is only a guide.

In order to avoid the risk of over-heating, the pumps should not be used at a flow rate below 10% of best efficiency point.

Symbols explanation:

- Q = volume flow rate
- H = total head

OPTIMA M (0.25 kW) – impeller diameter = 69 mm

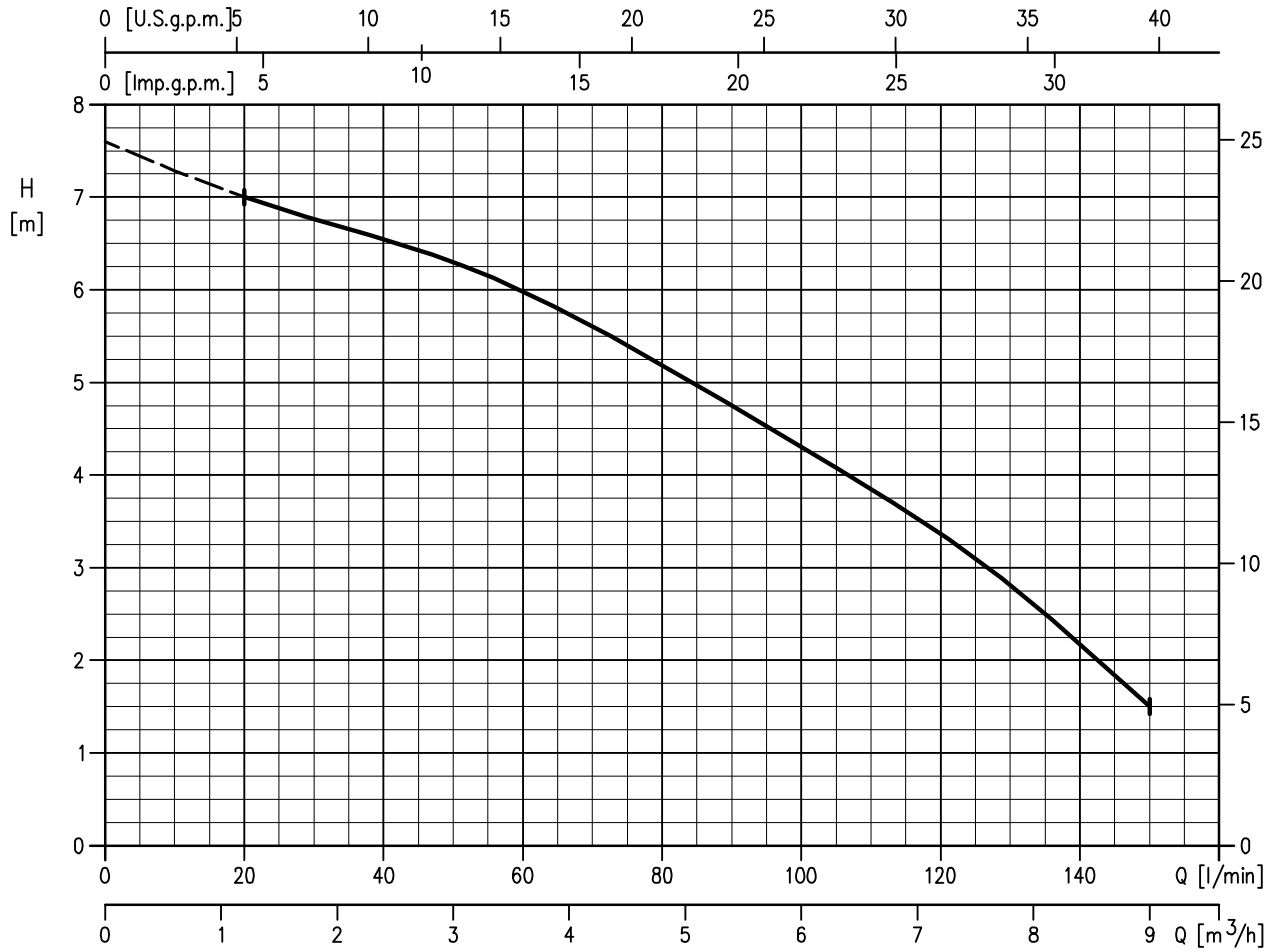

Rotation speed: $\approx 3400 \text{ min}^{-1}$
 Test standard: ISO 9906 – Annex A

SECTIONAL VIEW

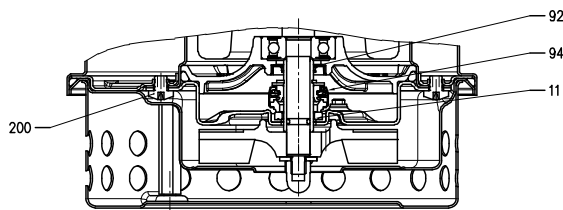
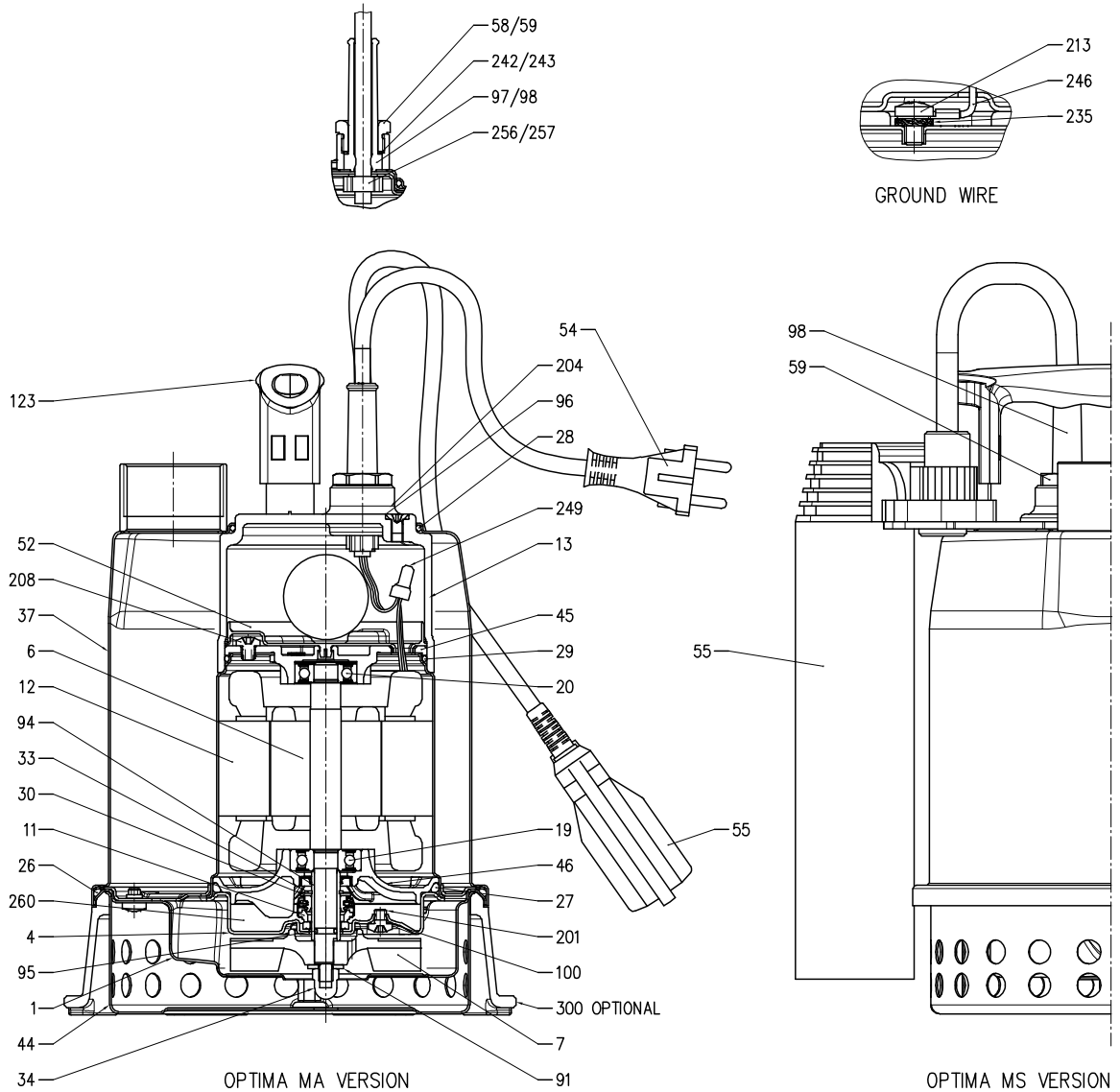

MOTOR FIXING

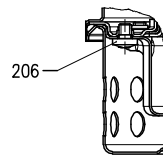

SUCTION COVER FIXING

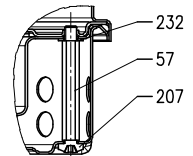

STRAINER FIXING

SECTIONAL VIEW TABLE

N°	PART NAME	MATERIAL	DIMENSIONS	STANDARD	Q.TY
1	Suction cover	EN 14301(AISI 304)	-	-	1
4	Casing cover	EN 14301(AISI 304)	-	-	1
6	Shaft with rotor	EN 14305 (AISI 303)	-	-	1
7	Impeller	PPE+PS glass fibre reinforced	-	-	1
11	Mechanical seal [1]	[1]	[1]	-	1
12	Motor frame with stator	EN 14301(AISI 304)	-	-	1
13	Motor cover	PP-GF30 class V-0	-	-	1
19	Lower ball bearing	-	-	-	1
20	Upper ball bearing	-	-	-	1
21	Adjusting ring	-	-	-	1
23	Capacitor	-	-	-	1
26	O-ring	NBR	159,5x3	-	1
27	O-ring	NBR	88,5x3,53	-	1
28	O-ring	NBR	75,87x2,62	-	1
29	O-ring	NBR	75,87x2,62	-	1
30	Washer	EN 14301(AISI 304)	12x2 1x1	-	1
33	Seeger ring	Carbon steel TC80	12	UNI 7435	1
34	Impeller nut	A2 - 70 UNI 7323	M 6	UNI 5721	1
37	Outer casing	EN 14301(AISI 304)	-	-	1
44	Strainer	EN 14301(AISI 304)	-	-	1
45	Upper bearing housing	EN 1706 AC-46000 D	-	-	1
46	Lower bearing housing	EN 1706 AC-46000 D	-	-	1
52	Terminal insulating base	PA 6 class V-0	-	-	1
54	Power cable	-	-	-	1
55	Switch [2] [3]	-	-	-	1
57	Spacer	EN 14301(AISI 304)	-	-	2
58	Power cable connector	PA 66-GF30	-	-	1
59	Switch cable connector [2]	PA 66-GF30	-	-	1
91	Washer	EN 14301(AISI 304)	-	-	1
92	Lip seal	NBR	22x12x4	-	1
94	Shaft sleeve	EN 14305 (AISI 303) ceramic coated	-	-	1
95	O-ring	NBR	6,07x1,78	-	1
96	O-ring	NBR	4,48x1,78	-	1
97	Power cable boot	NBR	-	-	1
98	Switch cable boot [2]	NBR	-	-	1
100	O-ring	NBR	4,48x1,78	-	1
123	Handle	PP	-	-	1
200	Screw	A2 - 70 UNI 7323	M 5x6	UNI 7687	4
201	Screw	A2 - 70 UNI 7323	M 5x6	UNI 7687	1
204	Screw	A2 - 70 UNI 7323	M 5x6	UNI 7687	1
206	Screw	A2 - 70 UNI 7323	M 5x6	UNI 7687	3
207	Screw	A2 - 70 UNI 7323	M 5x6	UNI 7687	2
208	Screw	A2 - 70 UNI 7323	M 5x6	UNI 7687	3
213	Screw	A2 - 70 UNI 7323	M 4x6	UNI 7687	1
232	Washer	PA 6	5,5x10x1	-	2
235	Washer	Zinked Steel	4	UNI 8842	1
242	Washer	EN 14301(AISI 304)	13,4x15,9x1	-	1
243	Washer [2]	EN 14301(AISI 304)	13,4x15,9x1	-	1
246	Ground wire	-	-	-	1
256	Cable holder	-	-	-	1
257	Cable holder [2]	-	-	-	1
260	Oil	Esso Marco1 152	-	-	40 cc
300	Minimum suction system [4]	Thermoplastic elastomer vulcanizate	-	-	-

[1] See pag. 303

[2] Only for automatic version

[3] It could be floating or magnetic type

[4] OPTIONAL See pag.700

BEARINGS

Pump Type	Ball Bearing	
	Lower side	Upper side
OPTIMA M	6200 ZZ C3	6000 ZZ C3

MECHANICAL SEAL

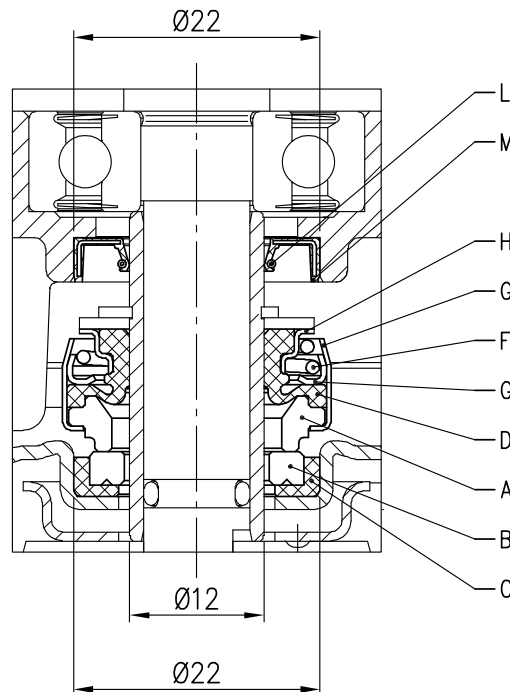

REF	PART NAME	MATERIAL product standard	MATERIAL optional
A	Rotary seal ring	Carbon graphite	SiC
B	Stationary seal ring	Ceramic	SiC - Q6 (*)
C	Gasket	NBR	FPM
D	Bellows	NBR	FPM
F	Self driving spring	EN 1.4301 (AISI 304)	
G	Frame	EN 1.4301 (AISI 304)	
H	Retainer ring	EN 1.4301 (AISI 304)	
L	Spring	EN 1.4318 (AISI 302)	
M	Lip	NBR	

(*) Special grade of SiC with microporosities filled with graphite

PUMP

OPTIMA MA

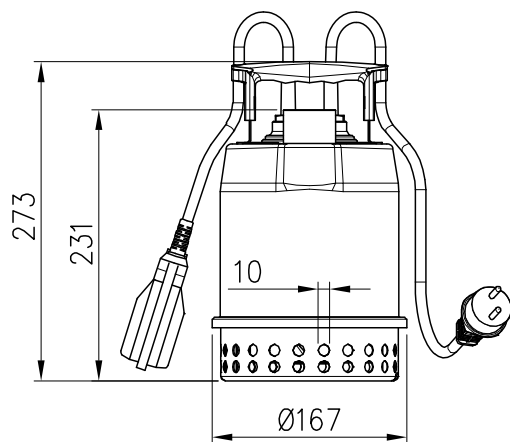

OPTIMA MS

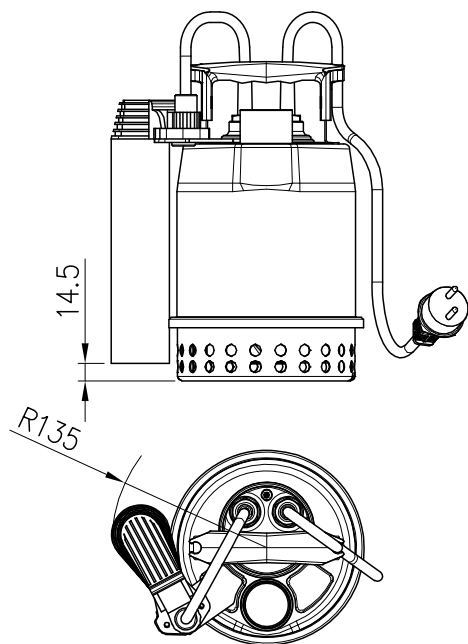

Pump Type	Weight [kgf]
OPTIMA M	4,2
OPTIMA MA	4,4
OPTIMA MS	4,6

PACKING

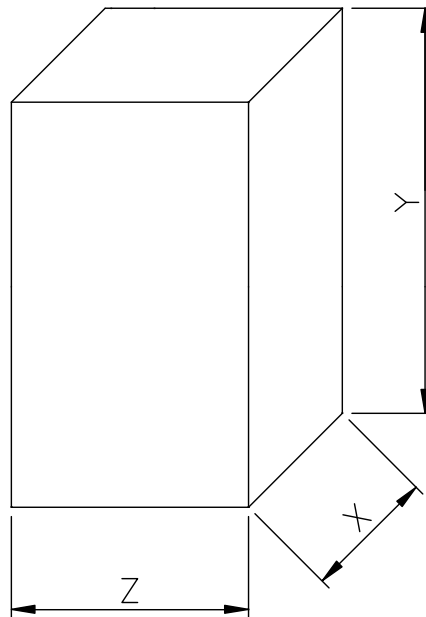

Pump Type	Dimensions [mm]			Weight [kgf]
	X	Y	Z	
OPTIMA M	180	330	220	4,7
OPTIMA MA				4,9
OPTIMA MS				5,1

MOTOR DATA

Pump type	Power		Capacitor				Input [kW]		Full load current [A]		Locked rotor current [A]	
	[kW]	[HP]	110-115 V		220-230 V		110-115 V	220-230 V	110-115 V	220-230 V	110-115 V	220-230 V
			π F	[V]	π F	[V]						
OPTIMA M	0.25	0.33	20	250	6.3	450	0.42	0.43	4.2	2.1	11.9	6.0

INSTALLATION

OPTIMA MA

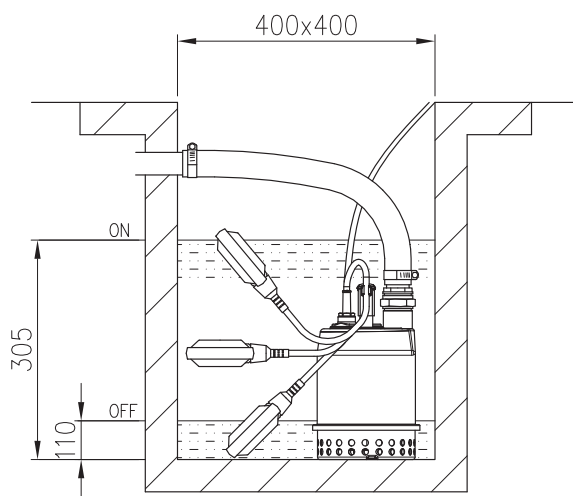

OPTIMA MS

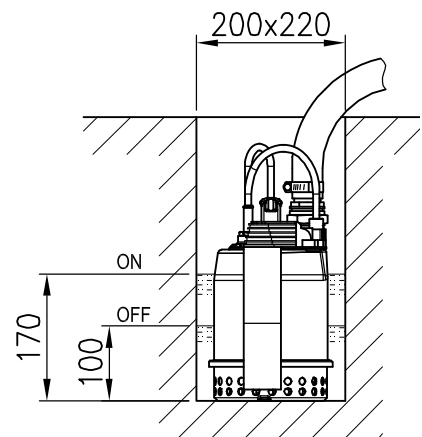

MINIMUM SUCTION SYSTEM

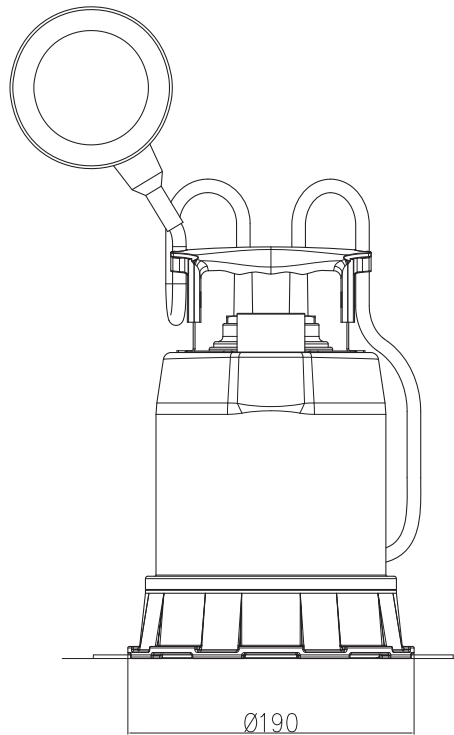

LEVEL	
Minimum starting suction level	10 mm
Minimum suction level capability	3 mm

COMPATIBILITY			
Type pumps	Version		
	M	MA	MS
Optima	✓	✓	✗